

SLIDING SERIES H30

SPECIAL PERFORMANCE

Electro-mechanical reduction gear available in 5 versions, for sliding gates up to 600 kg. The main structure is in die-cast aluminium, stove-enamelled with specific epoxy resins for outdoors.

VERSIONS

- H30/643** 230V • with built-in control unit • gate stop
- H30/644** 230V • with built-in control unit • magnetic gate stop
- H30/623** 24V • with built-in control unit • gate stop



TECHNICAL DATA

H30		H30/643	H30/623
		H30/644	
POWER SUPPLY	V	230	230 / motore 24V
RATING	W	240	90
THRUST	N	300	320
DUTY CYCLE	%	50	80
MOTOR OVERLOAD CUTOUT	°C	150	
WORKING TEMPERATURE	°C	-20+70	-20+70
PROTECTION RATING	IP	43	43
SPEED OF MOVEMENT	m/min	9,5	12
MAX GATE WEIGHT	Kg	600	600

DIMENSIONS

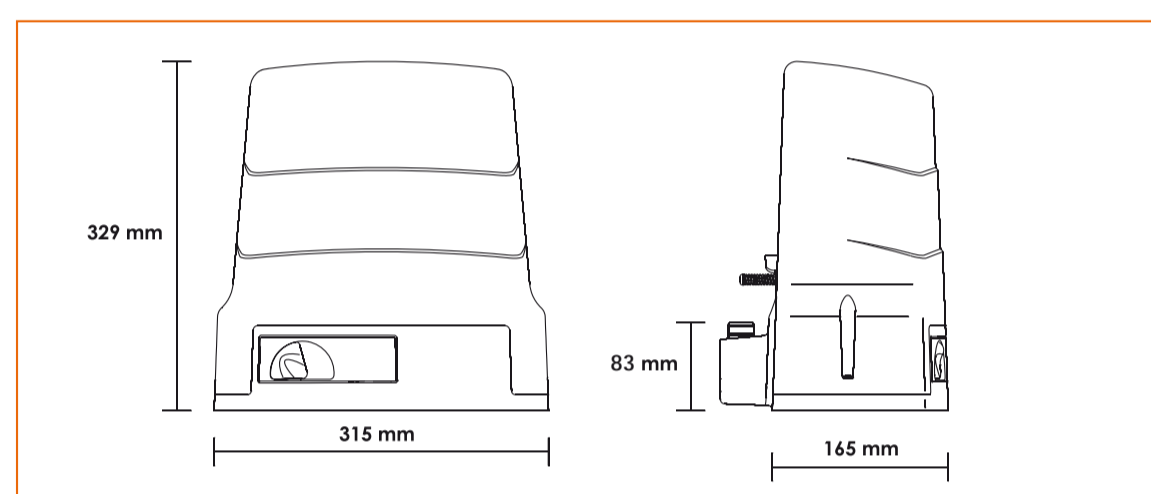

KIT



KIT H30

- 1 motor H30/... with control unit built in
- 2 remote control H80/TX22
- 1 photocells R90/F1E
- 1 radio receiver H93/RX22/I
- 1 flashing light R92/LR1
- 1 antenna for flashing light R91/AN1/LR1

VERSIONS KIT H30

- KIT H30/645 sliding gate automation up to 600 kg • gate stop
- KIT H30/646 sliding gate automation up to 600 kg • magnetic gate stop

ACCESSORIES



GA550
galvanised steel rack
22x22x1000
module 4



GA551
galvanised steel rack
30x12x1000
module 4 complete with spacers
and screws



GA552
nylon rack module 4
with 4 connectors
L 1000



GA553
nylon rack module 4
with 6 connectors
L 1000



MC751
gate stop
for control unit R70/1AC



MC752
gate stop kit
for control unit R70/1AC



MC753
magnetic gate stop
for control unit R70/1AC

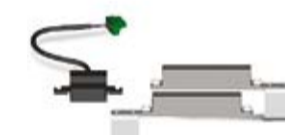

MC754
magnetic gate stop kit
for control unit R70/1AC

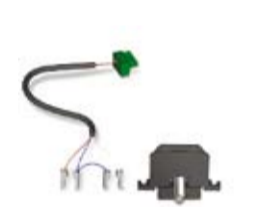

MC762
gate stop
for control unit H70/100AC



MC763
gate stop kit
for control unit H70/100AC



MC764
magnetic gate stop
for control unit H70/100AC

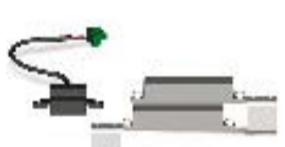

MC765
magnetic gate stop kit
for control unit H70/100AC



MC772
gate stop
for control unit H70/101AC



MC773
gate stop
kit for control unit H70/101AC



MC774
magnetic gate stop
for control unit H70/101AC



MC775
magnetic gate stop kit
for control unit H70/101AC



MC771
safety micro
for control unit H70/101AC



KT214
fixing plate
complete with stay bolts
and screws for H30



KT221
raised fixing plate
with stay bolts and screws for H30

"H30 style Roger Technology conceived with logic"

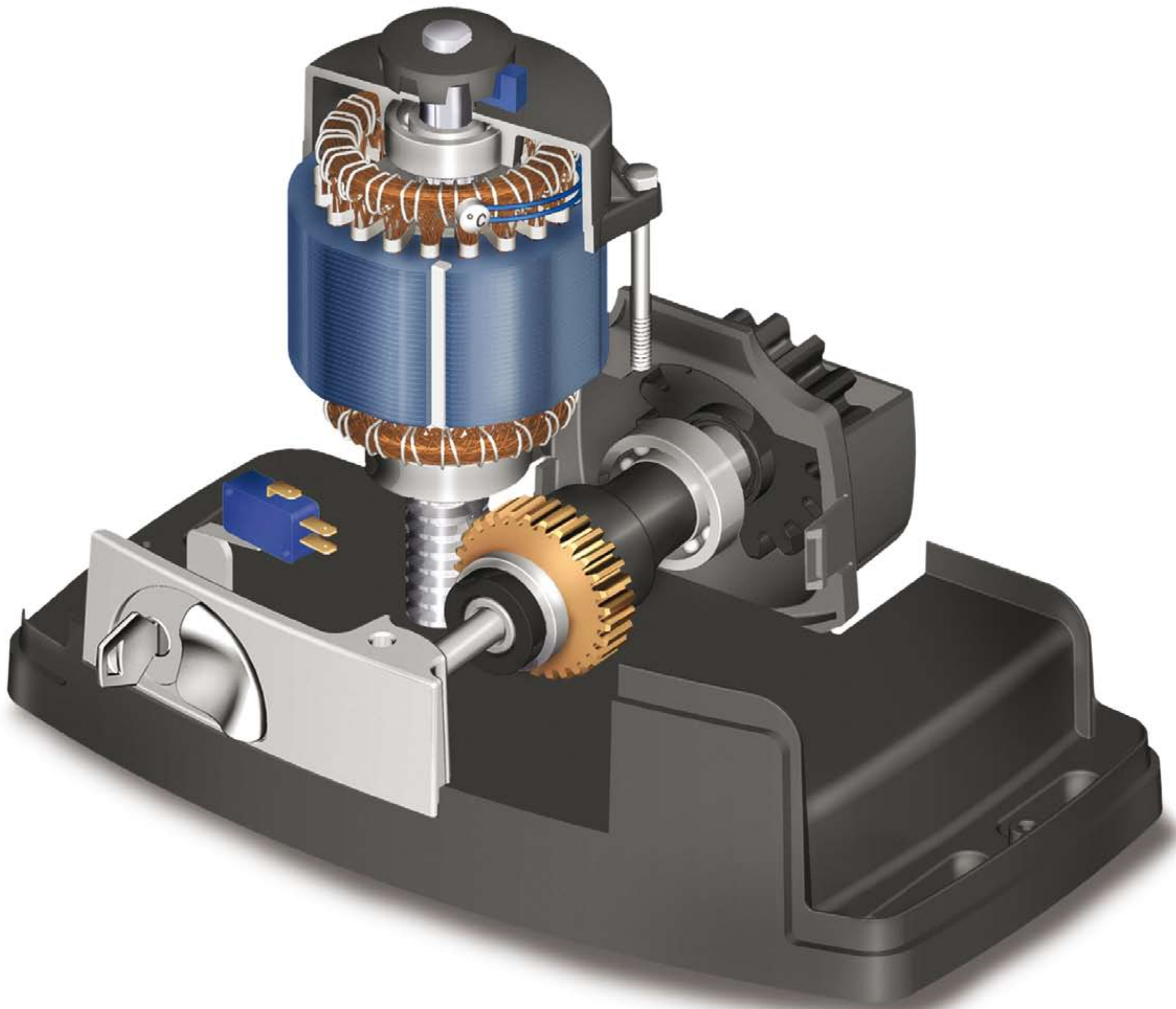

SURE RELEASE

The solid die-cast aluminium release handle with customized key allows release and manual movement of the gate at all time.

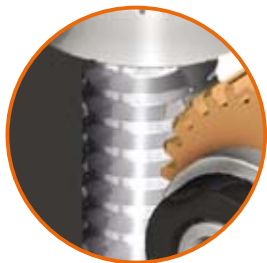

SMOOTH MOVEMENT

Worm screw in special steel with precision finish and hardening of the thread.



EVERYTHING IN PLACE

2 seals ensure perfect tightness with regard to the grease inside the reduction gear and at the same time keep water out.



BRONZE AND STEEL FOR PERFECT MATING

Bronze crown gear and steel worm screw with precision finishing and hardening of the thread to ensure perfect, low-noise and durable mating.



SOLID AND RELIABLE

The main structure is in die-cast aluminium.



TOTAL PROTECTION

Outgoing gear fully protected by an affective plastic shell.

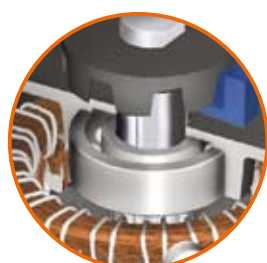

1400 PERFECT AND SILENT REVS FOR MINUTE

2 special precision bearings for electric motors.